

# TABLE OF CONTENTS

## Chapters

WARNING TO USERS ..... 2

**I.** Overview of the SST 450 ..... 3

**II.** Preparing the SST 450 for Testing ..... 4

**III.** Normal Testing ..... 5

**A.** An Example ..... 5

**B.** Average vs. Peak Measurements ..... 6

**C.** What Data Should be Recorded ..... 6

**D.** How to Interpret Readings ..... 6

**IV.** Testing Complex Surge Suppressors ..... 8

**A.** Multi-Element Suppressor Topologies ..... 8

**B.** General Test Routine Suggestions ..... 10

**V.** Service and Repair Information ..... 11

**VI.** User Maintenance of the SST-450 ..... 11

Warranty Statement ..... **Inside Back Cover**

## Appendices

**A.** Packing the SST-450 for Shipment ..... 12

**B.** Transient Voltage Surge Suppressor  
Principles & Testing Possibilities ..... 13

**C.** Display Message Descriptions ..... 29

**D.** Device-Specific Test Routines ..... 30

**●●●● HIGH VOLTAGE HAZARD ●●●●****WARNING TO USERS:**

**THE SST-450 CAN PRODUCE VOLTAGES IN EXCESS OF 2000V. ALTHOUGH THE CURRENT SUPPLIED BY THE TESTER ITSELF IS LIMITED TO A NON-LETHAL LEVEL, IT IS POSSIBLE THAT THE CAPACITANCE OF A DEVICE UNDER TEST CAN BE LARGE ENOUGH TO STORE A DANGEROUS AMOUNT OF ELECTRICAL ENERGY THAT CAN DELIVER A DAMAGING OR EVEN FATAL SHOCK TO THE USER.**

**ACCIDENTAL CONTACT WITH THE TEST LEADS WHILE THE TESTER IS OPERATING CAN DELIVER A PAINFUL SHOCK, AND EVEN THOUGH THIS IS UNLIKELY TO BE DIRECTLY INJURIOUS OR FATAL TO A HEALTHY PERSON, THE DRAWBACK REACTION TO THE DC SHOCK MAY CAUSE THE USER TO BE INJURED BY STRIKING NEARBY OBJECTS WITH GREAT FORCE. THERE MAY ALSO BE LIVE ELECTRICAL PARTS NEARBY THAT COULD BE CONTACTED BY THIS NATURAL DRAWBACK REACTION, CREATING AN ADDITIONAL HAZARD. FOR THIS REASON, THE SST-450 SHOULD NEVER BE USED IN CONFINED SPACES.**

**A GOOD PAIR OF LINEMAN'S GLOVES SHOULD PROVIDE REASONABLE PROTECTION AGAINST CASUAL BUMPING INTO LIVE TEST PROBES, BUT HASTILY, ILL-CONSIDERED MOVEMENTS CAN NULLIFY THE VALUE OF ANY SUCH PRECAUTIONS. THE TESTER WILL SERVE YOU WELL IF YOU OBSERVE SENSIBLE PRECAUTIONS, BUT MUST NEVER BE USED CARELESSLY OR UNDER DISTRACTING CIRCUMSTANCES. ATSI CANNOT AND DOES NOT ASSUME RESPONSIBILITY FOR INJURY OR DEATH ARISING OUT OF THE USE OF THIS TESTER. ELDERLY PERSONS AND THOSE WITH ANY INDICATION OF HEART PROBLEMS ARE STRONGLY DISCOURAGED FROM USE OF THIS TOOL.**

**IT IS RECOMMENDED THAT THE SST-450 BE USED ONLY BY EXPERIENCED PERSONNEL TRAINED IN ELECTRICAL SAFETY PRACTICES. THE PROCEDURES OUTLINED IN THIS MANUAL SHOULD BE CAREFULLY FOLLOWED TO ASSURE SAFE OPERATION OF THE TESTER.**

## I. OVERVIEW OF THE SST

The SST-450 is a simple instrument designed to test the wide array of surge suppressor devices available today. The SST-450 tester consists of a 1mA DC current source with up to 1000 volts of compliance. This means the tester has up to 1000 volts available to use in establishing the 1mA DC current through the test leads. By using a number of defined test procedures with the tester unit alone or in combination with device-specific test modules, the basic capabilities of most surge suppressors can be determined. The tester is able to perform up to 5000 tests with fully charged batteries.

Shown in *Figure 1* below, the tester unit itself consists of a small hand-held enclosure with a 16 characters-by-2 lines LCD screen and pushbutton switches that control tester operation. Two standard banana jacks on the front of the unit accept the test leads to connect to the suppressor or one of the device-specific test modules.

The basic test is designed to read the DC voltage at which a shunt-type surge suppression device begins to conduct. This is commonly represented by that voltage across the device when it conducts 1 mA DC, so the SST-450 is designed to produce this 1mA current and read the corresponding voltage. The only extension of this simple function is to provide two voltage readings:

- a peak reading that will indicate the voltage at which a device begins to conduct the 1mA test current
- an average reading that will indicate whether the device under test (DUT) “folds back” its voltage after turning on.



*Figure 1* SST-450 Tester

If the tester detects a capacitive load in the DUT, it will display the value of the capacitor and turn on a 5mA current source to charge the capacitor. After the capacitor is charged, the tester will switch back to the 1mA current source and perform the measurement. Depending on the value of the capacitor and the clamping voltage of the DUT, this process may take several seconds to perform the test. At the end of the test, if there is dangerous voltage present, the tester automatically discharges the DUT. A decreasing voltage is displayed during the discharge process.

It is recommended that you thoroughly read the Technical Supplement in Appendix B, “*Transient Voltage Surge Suppressors and Testing Possibilities*,” before proceeding with this manual or performing any tests with the SST-450. The technical supplement gives an introduction to the various types of surge suppression devices available and the means by which they can be tested. You will be required in most instances to have knowledge of the type of suppressor being tested before the data presented by the SST-450 can be interpreted as an indication of device capability.

## II. PREPARING THE SST-450 FOR TESTING

In its most basic configuration, the SST-450 uses two high-voltage test leads that are inserted into the banana jacks on the front of the tester. These leads have clips that attach to the leads of the DUT as shown in *Figure 2*. This is the method used to test any two-terminal discrete suppressors like MOVs. **IT IS VERY IMPORTANT THAT THE SURGE SUPPRESSOR BE REMOVED FROM THE CIRCUIT IT PROTECTS BEFORE TESTING.** This point is emphasized for safety reasons, to protect you, the tester unit, and the protected circuit, and also to assure a meaningful test measurement.

Many shunt surge suppressors are connected in parallel with others on the same circuit, especially when there is a common power bus, as in a traffic cabinet or similar installation, so the DUT must be isolated from the others before testing. In most cases, only one lead of a typical two-terminal device needs to be lifted to provide isolation. Often, two sets of tests should be performed, reversing the leads between each test. This depends on the type of suppressor being tested; once again, we note that knowledge of the suppressor type and characteristics is needed for testing (see Appendix B).



*Figure 2* Typical test setup

The SST-450 is intended to be a bench-top tester, but it is possible to use it as a field-portable unit if the isolation requirement described above is followed. This requires disconnecting components from the field circuit for testing, but otherwise follows similar test procedures.

### III. NORMAL TESTING

#### A. An Example

“Normal Testing” means testing a simple two-terminal surge suppressor with the basic test lead configuration described in Chapter II. As an example, we will describe how to test the V130LA1, a commonly-encountered MOV often used to protect the 120V AC line input to equipment. Since it is designed to protect normal AC line voltage circuits, we can expect the V130LA1 to clamp at a voltage somewhat higher than the peak of a 120V AC rms sine wave, which is about 170 volts, nominally. The manufacturer’s MOV data sheet tells us that for the V130LA1, the 1mA DC voltage, called  $V_{nom}$ , is between 184 and 255 volts (see *Figure 3* below). This is an “out of the box” (i.e., manufactured) tolerance. Thus, when we test the 1mA DC clamp voltage of the device with the SST-450, we should check to see that it falls within this range. Otherwise, it should probably be discarded.

RATINGS AND CHARACTERISTICS TABLE

MODEL NUMBER	MAXIMUM RATINGS (25°C)				CHARACTERISTICS							MODEL SIZE (mm)
	CONTINUOUS		TRANSIENT		$V_{NOM}$ VARISTOR PEAK VOLTAGE			MAX. CLAMPING VOLTAGE $V_C$ @ TEST CURRENT (8 x 20 $\mu$ s)		TYPICAL CAPACITANCE  $f = 0.1-1$ MHz		
	RMS VOLTAGE	DC VOLTAGE	ENERGY (10 x 1000 $\mu$ s)	PEAK CURRENT (8 x 20 $\mu$ s)								
	$V_{acm}$ VOLTS	$V_{DCM}$ VOLTS	$W_{tm}$ JOULES	$I_{tm}$ AMPERES								
V95LA7A V95LA7B	95	130	20	4000	134	181 165	207 170	280 250	50 50	1250 1250	14 14	
V130LA1	130	175	4	500	184	255	273	390	10	180	7	
V130LA2			8	1000		232	254	340	10	180	7	
V130LA10A			30	4000		232	254	340	50	1000	14	
V130LA20A			50	6000		232	254	340	100	1900	20	
V130LA20B			50	6000		220	238	325	100	1900	20	

*Figure 3 MOV Data Sheet. Source: General Electric, Transient Voltage Suppression Manual ©1978.*

The test procedure is as follows:

1. Remove the MOV from its circuit if it is not already isolated.
2. Clip one test lead to each lead of the device. Make sure the leads are not close to any other conductors, like wires that may be laying on the bench or a metal cabinet, etc.
3. Remove your hands from the test leads and DUT.
4. Turn on the SST-450.
5. Push the FORWARD test button and record the display values.
6. Turn the tester off.

In general, the test procedure above should include a REVERSE test, which is equivalent to reversing the Red and Black leads on the MOV. Although MOVs like the V130LA1 are symmetric and should give the same readings in both directions, some suppressors use back-to-back diodes that can fail only in one direction (see Appendix B), so it is important, in general, to perform both sets of tests.

## B. Average (A) vs. Peak (Pk) Measurements

The AVERAGE and PEAK measurement is a feature unique to the SST-450. A PEAK reading is the highest voltage across the suppressor before it begins to “turn on.” For crowbar devices like GDTs and TSPDs whose voltage drops when they “turn on,” this is the breakover voltage. An AVERAGE reading displays the average voltage seen across the suppressor. For clamp devices like MOVs and SADs, this reading will be nearly identical to the PEAK reading because the voltage of a clamp device does not drop when it “turns on.” However, for an operational crowbar device the voltage across the device drops after the breakover voltage is reached, so the PEAK and AVERAGE readings will be different. Because the SST-450 repetitively ramps up to the breakover voltage, a sawtooth-like voltage waveform results while testing of an operating crowbar device is underway, and the average voltage of such a waveform is lower than the peak voltage. The PEAK/AVERAGE readings allow you to quickly see if a crowbar device is operating after the breakover voltage is reached. Note that some crowbar devices (usually TSPDs) have a turn-on current ( $I_T$ ) of more than 1mA, the current supplied by the SST-450; in this case the PEAK and AVERAGE readings will be the same because there is insufficient current available from the tester to cause the device to “turn on.”

## C. What Data Should be Recorded

In most cases the maximum and average clamp voltages in each direction of a two-terminal device should be recorded. More complicated suppressors have multiple suppressor elements within them, and these must be tested individually to the extent permitted by the suppressor circuit's topology and external connections. It is for this reason that ATSI develops and maintains device-specific test procedures that guide SST-450 users through the testing of the more popular surge suppressors available from several manufacturers. The more complicated the suppressor circuit, the more data that must be recorded. This situation is described in section IV.A on page 8. Still, the test basically comes down to looking at the 1mA DC clamp voltage of the various individual protective elements within the suppressor circuit. Occasionally, we will use the current-source capability of the tester to check the condition of series elements like resistors and fuses, but this is more effectively done with an ohm-meter. You may construct your own test routines for specific devices, and you may consult ATSI for assistance or to request a custom test procedure design.

## D. How to Interpret Readings

Since no clear standards exist for installed suppressor testing (see Appendix B. ), the results of any SST-450 test are subject to your interpretation, but certain guidelines and suggestions apply. These can be grouped according to the type of suppressor being tested, and are summarized on the next page.

A failed device is indicated by any of the following:

#### **Metal-Oxide Varistors (MOVs):**

- a change of more than 10% from the installed device's original 1 mA DC clamp voltage
- a clamp voltage reading outside of the normal device tolerance,
- a significantly different reading between PEAK and AVERAGE clamp voltage displays on the SST-450

#### **Gas-Discharge Tubes (GDTs):**

- a significant change in breakdown voltage, such as 25% or more

#### **Silicon Avalanche Diodes (SADs):**

- a change of more than 5% from the installed device's original 1 mA DC clamp voltage
- a clamp voltage reading outside of the normal device tolerance
- a significantly different reading between PEAK and AVERAGE clamp voltage displays
- for back-to-back diodes, any significant imbalance of clamp characteristics in each direction

#### **Thyristor Surge Protective Devices (TSPDs):**

- a change of more than 5% from the installed device's original turn-on voltage
- a turn-on voltage outside the normal device tolerance
- lack of a difference between PEAK and AVERAGE clamp voltage displays
- any significant imbalance of turn-on characteristics in each direction

It should be clear from the statements above that the basic use of the SST-450 for evaluation of surge suppressor capabilities involves comparing the characteristics of installed devices to those of new devices (i.e., out-of-the-box), the idea being to catch any suppressors that may have been stressed due to their installation environment. It can also be used to screen new devices before they are installed. Although cumbersome, the best method for checking suppressors is to label each suppressor and maintain a written test record for each individual device, tracking it over time from installation to replacement. This can be useful in a number of ways:

- to evaluate various competing surge suppressor models for performance in the field,
- to indicate which areas of an installation are most prone to degradation from either surge events such as lightning or other environmental stresses such as temperature and humidity,
- to provide a written record as evidence of an ongoing maintenance program.

## IV. TESTING COMPLEX SURGE SUPPRESSORS

Many surge suppressors contain multiple surge suppressor devices in a somewhat complex circuit. Different circuit topologies are used by designers to match their suppressor to its intended use. High-speed communications circuits require a different type of suppressor than do power circuits or modems or antennas, and so forth. The possibilities are nearly limitless, but a few common suppressor circuit topologies are discussed here to help the user understand how device-specific test routines are generated and stress the need for a thorough understanding of a particular organization's inventory of surge suppressors.

### A. Examples of Multi-Element Suppressor Topologies

#### Line-Voltage Suppressor With Two MOVs:

Figure 4 shows the circuit for this simple type of line-voltage surge suppressor. It uses two MOVs to shunt surges into the safety ground wire from both the AC Hot and AC Neutral lines. This is the type often found in Type-170 cabinets, where the Caltrans specification requires a separate AC Neutral and Earth Ground. NEMA TS-1 cabinets can get by with just a single two-terminal MOV from Line to Neutral (or Ground).

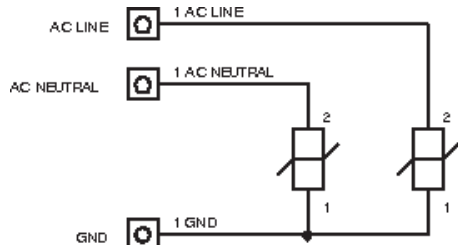

Figure 4 Line-Voltage Suppressor with 2 MOVs

#### Line-Voltage “Hybrid” Suppressor:

A hybrid suppressor usually combines several different types of surge suppressor elements. In the relatively simple example circuit of Figure 5 below, we see MOVs both upstream and downstream from a large inductor (typically over 200mH) that is intended to reflect the fast-rising surge energy at the input side of the suppressor.

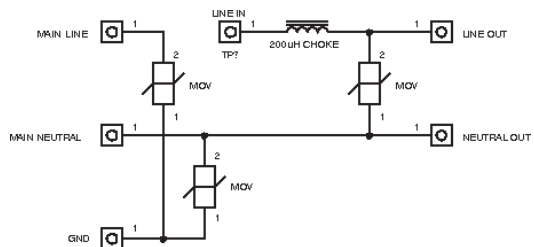

Figure 5 Line-Voltage “Hybrid” Suppressor

### Line-Voltage Suppressor With MOVs, SADs, and RFI filter:

Figure 6 below shows how a “simple” AC line protector topology can become somewhat complex. Here, two stages of surge protection are implemented using MOVs and back-to-back SADs separated by a typical RFI filter using inductors and RF suppressor capacitors. The inductors, if large enough, can behave like the choke in Figure 5. Like the previous example, this type would probably be called a “hybrid.” This circuit also has a third MOV from Line to Neutral on the input side.

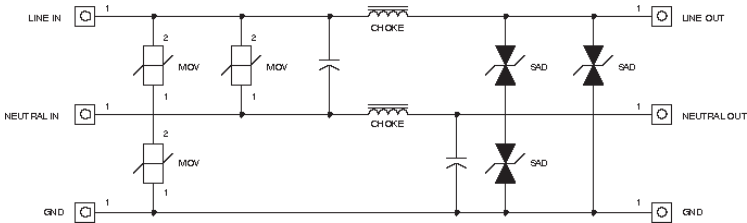

Figure 6 Line-Voltage Suppressor with MOVs, SADs, and RFI Filter

### Telecom Surge Suppressor:

Figure 7 shows the topology for a modern telephone network surge suppressor. This is much different from the carbon-block suppressors of old. This one shows three levels of shunt surge protection, beginning with a three-terminal Gas Discharge Tube followed by MOVs and, finally, by SADs. These shunt stages are separated by series resistance elements that limit the current between each stage.

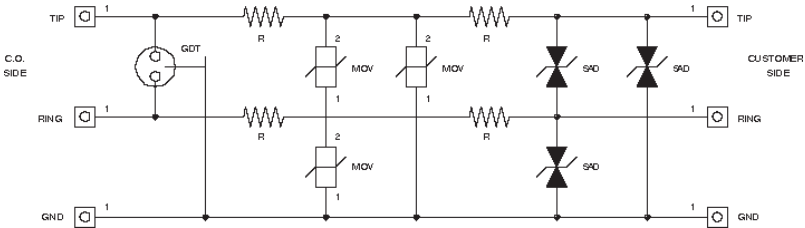

Figure 7 Telecom Surge Suppressor

### Data Line Suppressor:

The circuit of Figure 8 belongs to a very popular device in the traffic signal industry for protecting interconnect data lines. Each line pair is protected by a three-terminal GDT and back-to-back SADs, separated by a small series resistance.

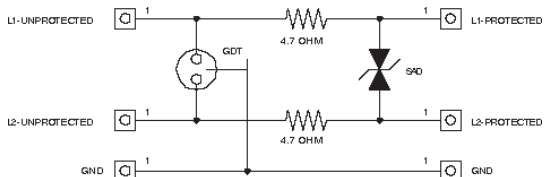

Figure 8 Data Line Suppressor

## B. General Test Routine Suggestions

When faced with using the SST-450 to test a device whose internal topology is unknown, we recommend that you call ATSI. ATSI will research the device and attempt to get specific information from the manufacturer that will allow creation of a test routine specific to that device. Otherwise, you will be forced to do the same, but manufacturers of surge suppressors are often reluctant to give details of device construction. ATSI has a constantly-expanding inventory of surge suppressors that is used to develop test routines for the SST-450. One bit of advice: if you wish to maximize testability, stick to surge suppressors from recognized and reputable manufacturers who will be there to provide both information and products in the future.

At the most basic level, the SST-450 is a tester of shunt type transient voltage surge suppressors. These are suppressors which connect across the lines of the protected circuit (i.e., in shunt) and limit the voltage that may be applied across those lines. In this sense, we can test any device by simply placing the SST-450 test clips on the protected lines and reading back the clamp or turn-on voltage. However, there are situations, like several of the previous example circuits above, where several stages are connected across the same two lines. In this case, the SST-450 will only test the suppressor (usually the downstream one, if it is operational) with the lowest clamp or turn-on voltage. Almost all of the multi-element surge suppressors are encapsulated with epoxy, so the remaining devices are simply untestable because they cannot be isolated from the circuit. This is analogous to the situation described above where the AC line protectors of equipment on an AC bus must be removed from the circuit. *Note: Some complex surge suppressing devices can have fault indication circuitry and filtering capacitors. This circuit creates a resistive load during testing of such devices and alters the correct measurement of clamping voltage. However, the measurements can tell if the protection circuit is working. A good example is the SHA-1250 from EDCO (test procedure on page 45).*

It seems logical, however, that the upstream suppressors in a multi-element circuit are required to handle the most surge energy, while the downstream suppressors have progressively smaller surge dissipating capability. This is not always the case, but a properly-designed surge suppressor will usually operate in this way. Thus, a failure of an upstream device from a very large surge is likely to cause a total failure of the downstream devices, and it is reasonably safe to assume that, if the downstream devices test “good”, then the upstream devices are also “good.” This means that even for multi-element suppressor topologies, the two-terminal test of the SST-450 gives an adequate indication of device capability. If in doubt, replace the suppressor anyway. For example, after a known lightning strike with immediate damage, it would be wise to replace at least the main upstream suppressor that protects the equipment, even if it tests “good.”

## V. SERVICE AND REPAIR INFORMATION

The SST-450 is sold with a one-year limited warranty to the original purchaser, as defined by the limited warranty on the inside back cover of this manual. No other warranties, expressed or implied, apply to the SST-450 or associated components. If it is necessary to return your tester to the factory, please refer to **Appendix A**, "Packing the SST-450 For Shipment," before giving it to your delivery service.

After the first year, ATSI will continue to provide repairs to the tester on a parts-plus-labor basis. A phone call describing the problem may allow ATSI to make a nonbinding estimate of repair costs, but the surest approach is to send back the tester for a comprehensive evaluation and a binding repair estimate. Please refer to **Appendix A** for packing instructions.

In order to be assured of optimum safety and performance of your tester, ATSI encourages you to return the SST-450 every year to the factory for calibration and recertification. Factory calibration restores your SST-450 to performance identical to that of new testers. In addition to calibration of the test parameters, this service includes replacement of batteries and firmware updates. Please contact the factory for price and scheduling information on this service.

## VI. USER MAINTENANCE OF THE SST-450

Because of the high voltages generated by the SST-450, most repairs require an intimate knowledge of its workings to be safe and successful. On the other hand, battery replacement is one maintenance task which can be easily performed by most technicians. If you use your SST-450 often for high-voltage tests, you may go through several sets of batteries per year.

The battery indicator (in percentage format) on the LCD indicates when the batteries in the SST-450 require replacement. There are two 9V alkaline batteries in the SST-450. To replace the batteries, you will need to open the battery cover on the backside of the tester.

**YOU ALSO NEED TO BE SURE TO TURN THE TESTER OFF. NEVER OPEN THE BATTERY COMPARTMENT WHILE THE SST-450 POWER IS ON.** Lay the tester face-down on a flat table, making sure that there is nothing underneath the tester that can accidentally turn the tester on. Remove the two Phillips head screws that secure the battery cover. The battery cover can then be removed and access to the batteries obtained. Installation is the reverse of this procedure.

**USE ALKALINE BATTERIES ONLY!**

All other types of services needed for the SST-450 should only be performed by an ATSI factory technician. Any attempt at servicing the tester yourself or by someone other than a ATSI technician will void the factory warranty. See the Warranty statement located on the inside of the back cover for full details.

## **APPENDIX A. PACKING THE SST-450 FOR SHIPMENT**

Sooner or later, your SST-450 may need to make the trip back to ATSI. It may be for a calibration or a possible repair. Proper packing will help assure that your tester arrives safely and in the same condition as when you sent it. Successful shipping is mostly a matter of good sense. It starts with deciding what needs to be shipped. You do not want to expose any more than necessary to the hazards of the trip. For example, if the shipment is for repair of the SST and a questionable test module, then the other test modules and carrying case need not be shipped. The test leads should always be shipped so they can be inspected for any small cuts or possible damage. ATSI will replace at no cost the test leads if it is determined that they are a possible safety hazard.

Once determined what is being shipped, each item should be wrapped separately in bubble wrap or some other form of packing and then placed in a box. For damage claim purposes, UPS recommends AT LEAST 2 INCHES OF CUSHIONING ON ALL SIDES OF THE CONTENTS of the box. Appropriate cushioning materials are foam-wrap, bubble-wrap or a good firm filling of foam "peanuts". The package must protect your SST against shock damage (the six-foot drop test) and puncture damage. Do not use a really flimsy box as the outside container, as it may rupture under impact.

In most damage cases, the carrier is not to blame. Failure to properly pack the tester may deprive the use of the tester for weeks while the carrier investigates the damage claim. A half hour spent in careful packing can save many hours of loss of use of the tester.

## **APPENDIX B. TRANSIENT VOLTAGE SURGE SUPPRESSOR PRINCIPLES & TESTING POSSIBILITIES**

The contents of this appendix was originally written by Kevin Deummel in 1998, as a technical supplement for our original surge suppressor tester, Model 400. This technical supplement gives an introduction to the various types of surge suppression devices available and the means by which they can be tested.

### **I. Introduction**

Transient voltage surge suppressors are widely used to protect electrical equipment from damage due to natural (usually lightning) and system-induced power surges on electrical power and signal lines. Many industry publications describe the application of these devices for protecting all sorts of sensitive equipment, although there is no clear design standard at this time (Ref. 1). Testing standards, whose usefulness is debated by many experts and manufacturers, exist for “new” surge protection devices and are intended to provide a comparison between various devices when they are being considered for a specific installation. The most comprehensive standards were published as IEEE 587 in 1980 and more recently as IEEE/ANSI C62.41-1991, “IEEE Recommended Practice on Surge Voltages in Low-Voltage AC Power Circuits.” An Underwriters Laboratories test standard (UL1449) also exists, and in keeping with the purpose of the UL, is concerned mainly with product safety rather than application. An Adjunct to UL1449, Performance Classification Testing Service, recently added by the UL is designed to test the performance of “cord-connected surge suppressors,” and it is unclear how many devices found in traffic control applications will be classified under the new UL testing method, which is not mandatory (Ref. 17). Based on field installation results over the last two decades, these and similar (e.g., CSA-TIL#A-24) testing standards are likely to be revised to strengthen the applied test surges, reflecting a perceived inadequacy in the original models of typical surge environments. The U.S. military is working on a CID (Commercial Item Description) to allow the military to purchase commercial surge suppressors, and this standard will most likely utilize the UL1449 Adjunct testing and possibly some additional tests. Obviously, the need for performance standards is currently being addressed by various agencies, and in the near future it will be possible to specify a surge suppressor for design based on meaningful test data.

On the other hand, an installed base of millions of surge suppressors with few anecdotal failure reports indicates that most installations are at least partly successful (Ref. 2), even though most TVSS purchases are probably made on a “trial and error” basis without much consideration of the device capabilities: if a suppressor fails repeatedly under the installed conditions, a more capable device is tried until failures reach an acceptable level. But what is an acceptable level of failure? For the traffic industry, where many agencies are on limited

budgets and cannot afford to gamble with the cost of cabinets full of expensive control equipment and the dangers of a dark intersection, a near-zero failure rate is necessary. To this end, a number of manufacturers produce many adequate transient voltage surge arrestors and suppressors for the traffic control and other industries. Again, these devices have in general proven to be very capable in the field, considering the relatively small number of reported failures. This means the installed devices are, over time, successfully absorbing and/or diverting many transients in the relatively harsh outdoor surge environment. Some of these TVSS models feature visual indicators and/or alarm circuits to alert maintenance personnel that the suppressor can no longer be relied upon to suppress surges on the protected lines. Most models, however are “black boxes,” which give no visible indication of the presence or level of protection. Many signal technicians have expressed concerns about their inability to determine the state of protection afforded by their installed power-line and signal-line TVSS devices, so ATSI set out to examine the possibilities for field and bench testing of TVSS units. The result was the SST-400 Surge Suppressor Tester, and aspects of its development are considered herein because they exemplify the capabilities and limitations of a practical TVSS tester.

There are several types of transient voltage suppressor devices (described below), and each type can probably be found being used to protect traffic control equipment. Ideally, a single tester should be capable of testing all of these types simply and inexpensively. Some of these TVSS types degrade with applied stress, while others are “all or nothing,” being capable of handling rated surges almost indefinitely with little or no degradation. Thus, a tester should provide not only an indication of the presence of protection, but, if possible, an indication of the level of protection remaining on those devices which degrade with stress. Also desirable is the ability to test the device in-circuit and active, so the protected equipment (such as a controller cabinet AC power bus or detector amplifier) could be tested in the field without disabling normal operation. For reasons which shall become clear as we discuss the typical traffic control equipment surge protection installation, the latter feature proved to be impractical, although not totally impossible.



*Photo 1 Most Transient Suppressors are “Black Boxes” whose internal topology is unknown.*

Both NEMA TS2 and Type 170 specifications specify transient withstand levels for all controller assemblies and enclosed equipment (Ref 3,4). This means all products which claim compliance with these standards should have been designed (and hopefully tested) to pass the described tests. The easiest and least expensive way to provide this transient immunity is with shunt MOVs on the

protected lines, and the vast majority of control equipment manufacturers choose this method. This means that the AC power input lines on each piece of compliant equipment in the cabinet are provided with their own internal transient protectors. However, the NEMA-specified level of protection is not consistent with the high level of exposure typically experienced by traffic controller assemblies, and therefore most cabinet manufacturers and/or agencies employ a separate main AC power bus (or primary) surge suppressor which has a higher surge energy rating and lifetime than what would be required to simply meet the NEMA requirements, which do not specifically call for a primary suppressor. The minimally-compliant assembly would probably not last long in the field before the protection would be eliminated. Type 170 standards specify similar surge-protection levels for both the cabinet and enclosed equipment. Although the standards also call for transient protection on I/O lines and loop detector inputs, the primary surge suppressor is the one whose condition signal technicians would most like to assess, since it is responsible for taking care of the greatest part of any line surge, sharing this duty to some extent with the downstream suppressors. However, it is the presence of the additional, parallel suppressors on all the connected controller equipment (CU,MMU, load switches, etc.) that makes live, in-circuit testing of the primary suppressor difficult. This is discussed in the next paragraph.

If one tries to perform a live, in-circuit test of a traffic controller cabinet, all of the operational interconnected powerline suppressors will respond to the applied test pulse or signal., but one protector will usually clamp first and pass all the test current because the installed device characteristics vary considerably, even if they are all of the same nominal type (such as the ubiquitous VL130-type MOV). The signal technician would have no idea which device among the several protectors actually is working without measuring the current through each. In order to effectively test the suppressors, they must be removed from the AC power line and tested individually. This is not practical because many of the suppressors are located inside the equipment boxes and are not accessible. Even if the box-level ( i.e., controller, monitor, etc.) AC line suppressors are ignored by lifting the wires off the primary suppressor for testing, it is still necessary to turn off power to the controller assembly. This is also impractical under most circumstances. One possibility would be to add in an isolation and bypass switch



*Photo 2 Field testing of cabinet primary surge suppressor with a dark intersection. An extra person was needed to direct traffic during the time of no indications.*

to each cabinet to facilitate periodic testing without removal of the primary suppressor or powering down the intersection. Photo 2 (on page 15) shows field testing of control cabinet primary surge suppressors with a dark intersection. Total down time was typically 2-5 minutes per intersection, depending upon cabinet wiring and suppressor type. Although it is possible to test in the field, a suggested maintenance procedure uses the tester as a benchtop tester only, except in emergencies or other situations when the intersection will be dark. Ideally, a rotating pool of identical suppressors should be used to “swap out” installed suppressors at a predetermined maintenance interval, any time the intersection is dark for other maintenance procedures, or when a known surge event (e.g., lightning strike) has occurred.

## II. Types of Transient Voltage Suppressors

The development of various types of surge suppressors has followed electronic device developments and increased utilization of sensitive electronics such as computers and microcontrollers. Suppressors can be divided into two major categories: shunt-mode and series-mode (see Figure 1). Most devices are of the shunt-mode type, which divert surge current through the suppressor rather than let it go through the protected equipment. Gas discharge tubes (GDTs), carbon-block spark gaps, silicon carbide varistors (SiCVs), metal-oxide varistors (MOVs), silicon avalanche (“zener”) diodes (SADs) and thyristor surge protective devices (TSPDs) are examples of shunt-type devices. Shunt-mode devices can be further classified as being either clamp or crowbar devices, as explained below. There are also “hybrid” devices, the term being applied rather loosely, so “hybrid” could mean any number of things. Generally, hybrids have an active control circuit to cause a current-shunting component to turn on. Often, “hybrid” means that there are series devices or filters between two or more clamp stages, etc. Series-mode devices are sometimes called hybrids. Equipment-level series-mode devices are a fairly recent development and act to block the surge on the line before it reaches the protected equipment by including a big series inductor. They usually don’t absorb the surge energy themselves, but return it to the line gradually. This requires a somewhat complicated circuit (see Photo 8). A description of the various transient voltage suppressor devices follows. Most of these devices and their applications are described in NCHRP Report 317: Transient Protection, Grounding, and Shielding of Electronic Traffic Control Equipment (Ref. 16).

### A. Gas Discharge Tubes and Spark Gaps

Because of its overhead wiring and relatively low-voltage operation, the telephone network was one of the first places where surge suppressors were applied. The telephone network interface was originally protected at the building entrance from lightning-induced and power-line crossover surges by carbon-block spark gaps, which consist of blocks of carbon with a small gap of atmo-

spheric air that breaks down under the high voltage of a surge to become nearly a short-circuit until the arc induced across the gap is extinguished (Ref 5). The breakdown voltage of a carbon block gap is high (300V to 1kV for a typical 3-mil gap) and variable compared to newer suppressor types, so it is rarely seen in this application anymore. It was replaced initially by the gas discharge tube on most telephone interfaces because the GDT has a lower avalanche (or “turn on”) voltage ( 0.5-250kV) and can carry more current. Both of these devices were fairly successful for protecting telephone lines with traditional, robust electro-mechanical components. The GDT is sealed, not open to the atmosphere like a carbon gap, and it contains gasses at less than atmospheric pressure. Some GDTs are three-terminal devices, while others are two-terminal devices like the neon lamps often seen protecting the inputs to loop detector amplifiers (see Photo 3).

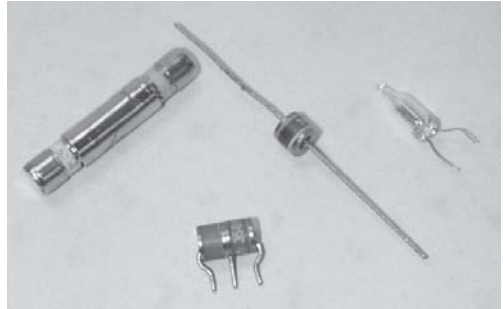

Photo 3 Gas Discharge Tubes

When the surge-dissipating voltage drop of a device is lower than its normal operating (or withstand) voltage, it is called a crowbar device because the voltage folds back like a crowbar as the device “turns on” (see Figure 1). Both carbon-block spark gaps and GDTs are crowbar devices. Once a GDT begins to conduct, the current will continue to flow at the low turn-on voltage until it is interrupted externally or brought below a certain minimal level called the holding current. This characteristic of GDTs is called follow-on.

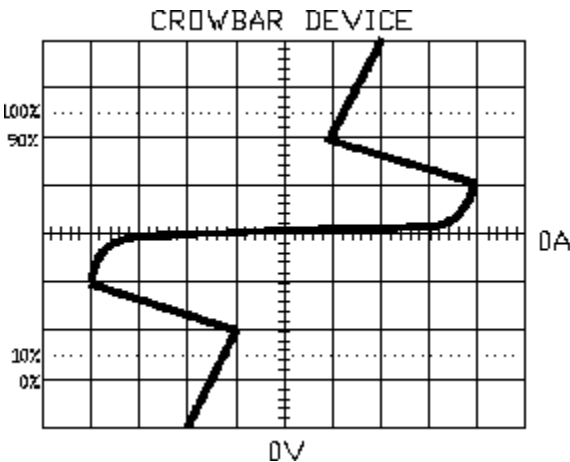
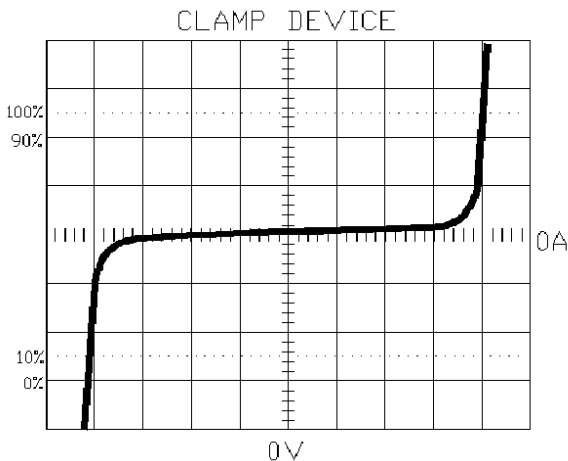

Figure 1 Crowbar Device Characteristic V-I Curve. The breakover voltage is that extreme where the curve begins to fold back. The voltage at the point at which it stops folding back is the turn-on voltage.

## B. Silicon Carbide Varistors

A varistor is a variable resistor whose resistance varies in a non-linear manner with applied voltage. In a varistor, the current starts out small, becoming much larger when the applied voltage exceeds a certain value, called the breakdown or clamp voltage. Thus, they can be used as transient suppressors to clamp surges to acceptable voltage levels. A clamp suppressor like the varistor “turns on,” or clamps, at a voltage exceeding the normal circuit voltage, as opposed to a crowbar device, whose voltage drops when it “turns on” (see Figure 2). Early varistor surge protectors were composed of the ceramic silicon carbide and were usually used in conjunction with a GDT because of their high standby, or off-state, current. Thus, they can be used effectively on high-voltage circuits such as power distribution transformer primaries (see Photo 4), but they are not often encountered in low-voltage applications. Use of SiC varistors decreased after metal oxide varistors (MOVs) became commercially viable in the 1970s (Ref 6), and it is unlikely that any will be encountered in traffic controller assemblies.



*Figure 2  
Clamp Device V-I  
characteristics. The  
voltage on the near-  
vertical portion of  
the curve is the  
clamp voltage.*

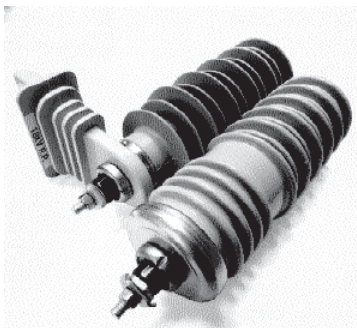

*Photo 4  
Varistors for Power  
Distribution Surge  
Protection.*

### C. Metal Oxide Varistors

The MOV is composed of sintered metal oxide crystals, primarily zinc oxide, ZnO. It exhibits the same nonlinear I-V characteristics of the SiC varistor, but it has more pronounced nonlinearity and a much lower standby current. They are relatively inexpensive and easy to apply, and they are by far the most widely used type of surge suppressor, with ratings from around 10VAC to several kilovolts AC. They are not perfect, as many manufacturers of the newer series-mode devices are quick to point out, but the advantages of series-mode devices are mainly for interconnected equipment with multiple safety ground references such as computers and peripherals in a LAN. The installed base of MOV-type devices and their relatively low rate of reported failures (ref 14) indicates that for the isolated traffic controller cabinet where the enclosed equipment is in close proximity and tied to the same local safety ground reference, MOVs offer adequate protection. Thus, they will continue to be the dominant type of primary (i.e., mains) traffic controller suppressor technology encountered, at least in the near future.

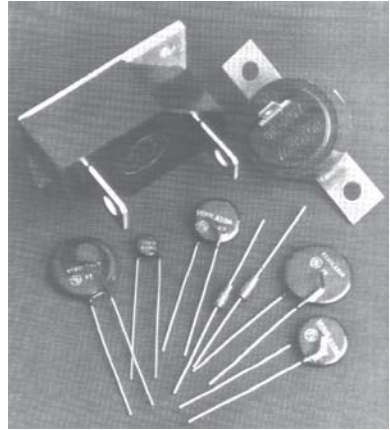

*Photo 5 Metal-Oxide Varistors. These come in a wide variety of packages. Only a few are shown here.*

### D. Silicon Avalanche Diodes

The silicon avalanche diode surge suppressor consists essentially of an avalanche diode with a large junction area to safely pass high transient currents. They are more often seen protecting low-voltage signal lines rather than AC power lines because of their low available breakdown voltage. They can clamp a large current (up to several hundred amps) to voltages as low as 6-7V. Because of their planar construction on silicon wafers, SADs tend to be more expensive than the bulk-sintered MOVs in comparable ratings. SADs are clamping devices like varistors; their "on" voltage is higher than the normal circuit voltage. Sometimes SADs are backed up by MOVs in the same package. SADs often contain two diodes back-to-back in a single package to provide bilateral protection (see Photo 6). It is possible in such cases for one diode to fail while the other remains

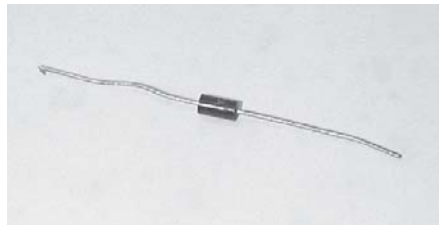

*Photo 6 Silicon Avalanche Diode Surge Suppressor*

unchanged because, for a given unidirectional surge current, the reverse-biased junction dissipates much more power than the forward-biased junction. Thus, it is important to test these devices with currents from each direction by reversing the test leads. Figure 3 shows how a bilateral SAD can be degraded in only one direction by a unipolar surge.

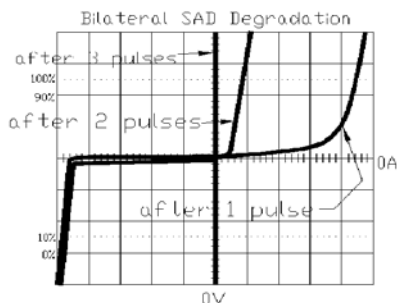

Figure 3 Bilateral SAD Degradation

## E. Thyristor Surge Protective Devices

The TSPD is a silicon device like the SAD, but it is a three-terminal device triggered into a conductive state by a surge that makes the device “crowbar” into a low on-state voltage well below the normal operating circuit voltage. Thus, for a given surge current, the crowbar device will dissipate less power than a clamp device like an SAD. The TSPD is available with ratings up to several hundred amps. “Hybrid” protectors are often of the TSPD type, the turn-on pulse coming from an avalanche diode with action similar to the SAD protector. Most TSPDs only have two leads because the turn-on (or gate) pulse is supplied by the protected line. Like the GDT, the TSPD has a follow-on current and must be “extinguished” once it turns on. They are often encountered on telecom circuits as discrete two-terminal devices (see Photo 7).

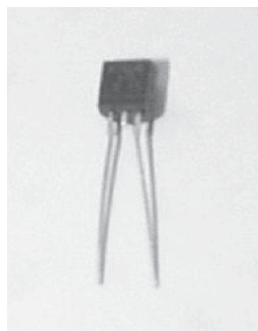

Photo 7 Thyristor Surge Protective Device

## F. Series-Mode Devices and Hybrids

So-called series-mode devices are the newest type of transient voltage suppressors. Since a typical surge is relatively short (on the order of 100 microseconds), its energy, despite the seemingly enormous magnitude of the surge current and voltage, is not too great in most environments to be largely reflected away from protected equipment by a large inductor and the remainder stored in reasonably-sized components, usually electrolytic capacitors. This is the idea behind series-mode devices, which use a rather complicated circuit to affect this goal. They usually include several banks of capacitors in addition to a large inductor as shown in Photo 8. This large inductor will reflect much of the surge energy back into the power line, rather than absorb it.

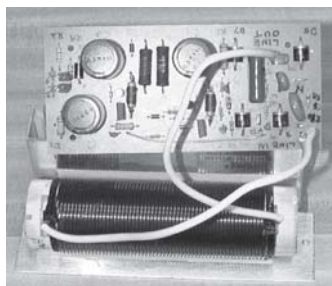
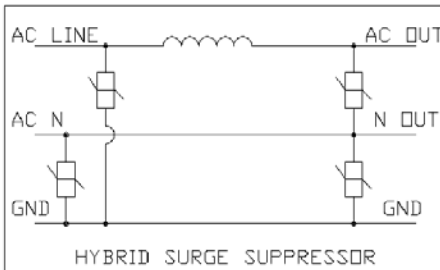

Photo 8 Open-frame Series-Mode Transient Suppressor

At the protected equipment, the surge is clamped to a voltage level slightly above the normal peak of the line (about 169V for a 120VAC line), and after the surge has ended, the small amount of stored energy that coupled through the big series inductor is gradually released back into the load. Because of the series inductor and its associated resistance and reactance at line frequency, a series-mode protector will have a continuous service current rating, such as 15A. This is the easiest way to tell if your “black box” contains series elements. For very large surges, some of the surge current will be shunted across the protected lines, but not all of the current is shunted as a shunt-mode device would do. This means there is very little neutral-line contamination in a series-mode device, a trait that makes them attractive for protecting power lines to interconnected equipment separated by some distance, such as computers and network printers in an office environment. Figure 4 below shows the configuration of a typical hybrid surge suppressor.



*Figure 4 Typical hybrid suppressor with MOVs and choke inductor. There is an almost endless variety of suppressor circuit topologies, so adequate testing of a suppressor requires knowledge of the circuit.*

### III. Failure Mechanisms in Transient Voltage Surge Suppressors

Obviously, devices used to protect electronic equipment from transients due to lightning and other high-intensity occurrences are going to be exposed to potentially damaging or destructive events. Sometimes the device itself provides an indication of failure, such as indicator LEDs, tripping of an upstream circuit breaker or visible damage to the device package itself. Pass-through devices that are common on signal lines can fail as opens, so the loss of a communication link, etc. will expose a failure. Many protectors, including most currently-installed devices, have no external indicators, and those that do have them are rarely checked. Some devices, most notably MOVs, are subject to degradation that reduces their surge suppression capabilities. It is necessary to understand the failure mechanisms and device topology to choose measurement parameters for TVSS testing. The failure mechanisms of the most common types of transient suppressors are discussed below.

## A. Gas Discharge Tubes and Spark Gaps

Carbon-block spark gaps can degrade when they are subject to repeated discharges because the blocks can wear, etc. This can cause the gap to widen, with a corresponding increase in breakdown voltage. They can fail as opens or shorts, depending upon the condition of the blocks, which can fall together to form a short. Gas discharge tubes, because they are sealed in glass or ceramic tubes, can become contaminated with plain old atmospheric air if the seals leak. This greatly increases their breakdown voltage and leakage current. They can fail as opens, shorts, or partial shorts (ohmic), depending upon whether the failure results from leakage only (open) or electrical stress that evaporates the electrode metal inside the sealed tube (short or ohmic). Typical "good" GDT leakage currents are very small, and a larger leakage current indicates a failed device. Likewise, a deviation from the nominal breakdown voltage warrants replacement of the protector. Nominal device tolerances are high for most GDTs, typically around +/-20 percent.

## B. Silicon Carbide Varistors

SiC varistors are unlikely to be encountered protecting low-voltage circuits on the utilization side of most electric power systems (Ref 7). They have been used in distribution and station-class surge arrestors in a manner similar to the more common MOVs. Nonetheless, when they do fail, they behave similarly to MOVs, discussed below.

## C. Metal Oxide Varistors

Despite being relatively simple devices to produce and apply, the actual microscopic failure mechanisms of MOVs remain something of a mystery (Ref. 8,9,10). Although an MOV can generally be expected to fail as a short, the measurable symptoms of degradation can vary widely, even under controlled conditions (Ref. 11). Results are similarly varied for field-installed devices. This makes testing difficult to implement and performance tolerance hard to define, since both can be rather subjective. However, the desire of most technicians is to have a simple, easy-to-use tester where previously there was none, and by keeping things simple, a useful tester can be designed. MOVs are not only the most common type of surge suppressor, but they are also the most susceptible of the solid-state TVSS types to degradation, so any TVSS tester will be primarily designed to test MOVs. MOVs have three main modes of failure: thermal runaway, puncture, and cracking (Ref 8.).

Thermal runaway occurs in an MOV because the leakage current increases with temperature. If the temperature of the MOV increases to the point where it cannot dissipate the heat generated by its rather small leakage current, the device will begin to heat up. As it does so, its resistance drops and more current

flows, so the MOV becomes even hotter, and so on until it ultimately burns up (i.e., catches on fire) or passes so much current as to trip any protecting fuse it might have. Some MOV module manufacturers include a fuse in series with the device for this purpose and to drive any indicator LED networks (see Figure 5). Other manufacturers simply assume the MOV will sink a big enough current to trip an upstream breaker or fuse (this is why an MOV-protected power circuit should always have an upstream interruptor). This approach will certainly let you know when your primary-protector MOV has failed because the intersection will go dark! The measurable consequence of thermal runaway as it is occurring is a decrease in the blocking resistance of the MOV under normal voltage stress, making that region of operation appear more and more ohmic (see Figure 6) for currents below the normal breakdown current,  $I_{brk}$ . There is no established standard for specifying breakdown current, but in many cases it is defined as that current for which the average current density in the MOV is  $1\text{mA}/\text{cm}^2$ . The disk-type MOVs that are most familiar increase in area as their current handling capability increases, so  $I_{brk}$  varies with each different size. However, satisfactory results will be obtained by defining the breakdown point for all MOVs at  $1\text{mA}$  total current, regardless of package size. A useful test measures the voltage at  $1\text{mA}$  for all devices; for “good” devices, this will give very close to the nominal breakdown voltage of the device ( $V_{nom}$ ), while for “bad” devices the voltage will be considerably lower (or, occasionally, higher). As devices degrade over time and with electrical stress, the breakdown voltage will generally decrease. A change of 10% or more from  $V_{nom}$  is recommended as a performance tolerance (Ref. 6).

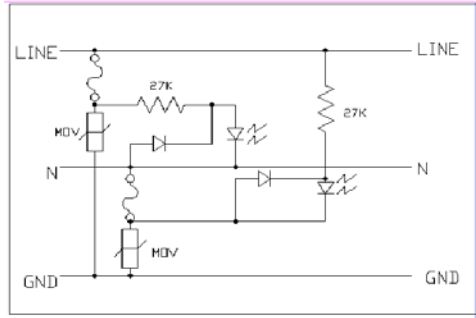

**Figure 5** Typical MOV-based surge suppressor with LED indicator circuit. The indicator circuit prevents a low-current tester from reading the MOV clamp voltage because the LED circuit presents a much lower impedance than the MOV. In this case, a tester with at least  $15\text{mA}$  of available current would be needed to test the  $120\text{VAC}$  line voltage suppressor.

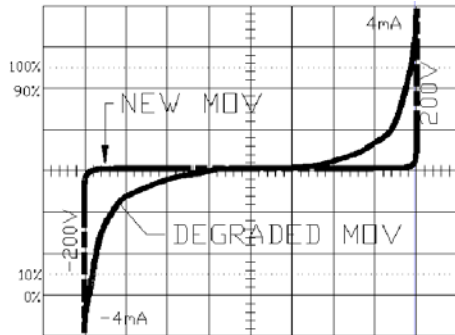

**Figure 6** Thermal runaway characteristics in a small MOV.

Puncture is another mode of failure for MOVs, chiefly from high-current pulses (Ref. 12). For field-installed devices such as those in controller cabinets, it is a likely form of failure from a direct or nearby lightning strike. A puncture is a natural consequence of the non-uniformity of the sintering process. There will always be some point-to-point variation in the breakdown voltage on the surface of the MOV, with the result that certain areas will conduct more current than others. This may result in localized melting of the oxide and create a conducting hole in the device that basically acts as a short circuit.

Cracking occurs when the surge is short enough to cause a localized heating of the MOV that creates a large enough thermal gradient in the bulk of the device to cause thermal stress fractures that split the MOV into pieces. If the pieces separate, the failure is as an open circuit. If they are held together by encapsulant or by packing with other components, a short or intermittent short will result.

#### D. Silicon Avalanche Diodes

The SAD transient-suppressor is basically just a bigger version of the familiar avalanche (“zener”) diode used in voltage regulators and as protection on CMOS IC inputs, etc. By making the junction area large (several mm on a side), the device is able to pass very high currents (up to several hundred amps) for short times without exceeding its thermal ratings. The design of a SAD is something of a balancing act: a trade-off between current capability and breakdown voltage. The current-carrying capability of the junction is proportional to its cross-sectional area and also to the doping concentration on the lightly-doped side. The breakdown voltage, however, is inversely proportional to dopant concentration. Generally, the higher the voltage of the line we are trying to protect, the higher we want the current capability to be, so the two parameters are in opposition. Under reverse bias (all SAD suppressors operate in the reverse bias region while protecting a line) the electrically-neutral depletion region at the junction can punch through the lightly-doped region if that region is made too thin in an effort to reduce the on-resistance of the diode or if the junction is not uniform (the larger a junction becomes, the harder it is to control this uniformity). This punch-through is manifest as a soft, non-avalanche breakdown and will be a likely cause of non-catastrophic damage under a

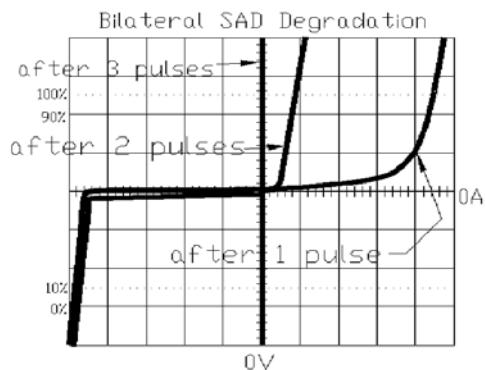

*Figure 7 P6KE220CA SAD degradation under ~300mJ pulses. Note how only the reverse-biased junction degrades and fails because of its higher power dissipation. The clamp voltage drops as the device is stressed.*

large, fast voltage surge. It is possible for SADs to suffer a partial punch-through or avalanche breakdown which can degrade the junction without causing it to go all the way to a short (see Figure 7). This can be detected as a decrease in the breakdown voltage  $V_{brk}$  of the SAD or as an increase in the standby current (Ref. 19,20). For the most part, however, SADs that have experienced large surges are either fully functional or completely shorted because it requires a surge of exactly the right energy to produce degradation effects. Figure 7 also shows why it is important to apply a test current both directions on a bilateral SAD; under a unilateral pulse, the reverse-bias junction fails first, because for a given current (which flows through both junctions), the reverse-bias junction drops its breakdown voltage while the forward-bias junction only drops the typical 0.7V of a silicon diode.

## E. Thyristor Surge Protective Devices

A TSPD will be subject to failures similar to those experienced by SADs because they are both silicon devices. Often, a TSPD will use an SAD as the triggering element for the thyristor. Other devices use a reactive drive circuit that responds to rapid voltage changes on the protected line. This is more typical of the hybrid devices described below. When overstressed, TSPDs will fail as a short, in a manner very similar to SADs.

## F. Series-Mode and Hybrid Devices

Hybrid devices often contain MOVs or SADs that will clamp a 1mA DC current, but only the MOV or SAD will be tested; any backup devices (GDTs or MOVs typically) will respond only if the lower-breakdown device is not available because it has failed open or in some other manner been isolated from the backup protector. Sometimes hybrids that contain RF filters between clamp stages are called "series devices." A true series-mode surge suppressor has passive series suppression components that react to the high-frequency surge energy but pass all lower frequencies. This includes the normal 60Hz line frequency, but more importantly, DC. This means that a DC current test of a true series-mode device is impossible, they will not clamp a slow (or DC) surge like an MOV or SAD will. To test, it is necessary to hit the suppressor with a voltage pulse and check the attenuation at the output end. Series-mode devices have active thyristor drive circuits that respond only when a certain  $dV/dt$  has been detected. They will not clamp a slower  $dV/dt$ . Thus, a pulse test must be applied of short enough duration and/or sufficiently high slew rate to detect a protection response. In a typical series-mode protector, over 200A of slow surge current must be delivered before any active stages turn on. A peak detect circuit could be used to hold the highest let-through voltage for the device as it responds to a specific test pulse, but it is not possible with a simple low-power tester to perform a standard test that will yield comparable readings for different suppressors, such as models from different manufacturers. Thus, because most series-mode

devices are active and contain more than a single protective circuit element, only a very cursory examination of their capability is provided by any simple tester, and any degradation will be nearly impossible to detect. However, it is a trait of the series-mode devices that they are not as subject to degradation as other types (if at all), and many contain indicator LEDs that warn of a failed device. For the most part they can be expected to perform almost indefinitely when not subjected to pulses beyond which they are rated. If this should occur, the probable mode of failure is an overstressed electrolytic capacitor, which will usually fail as an open, and the indicator circuit will show the unit to be damaged. Unfortunately, the indicator LEDs do little more than test for the presence of the storage capacitors, and it is necessary to turn off the main power and watch for the LED to remain lit for a few seconds, indicating the capacitors are still able to store charge. Hybrids often contain MOV shunt elements in addition to the passive inductor, so the clamp portion of the circuit may still be tested. The inductor, because it is constructed of heavy-gauge wire around an iron core, can be assumed operational as long as it has not been damaged or burned open by a very large surge.

#### **IV. Transient Voltage Suppressor Test Procedures**

There is no established test procedure for transient suppressor devices. NCHRP Report 317 (Ref 16) does not address the issue of testing surge protectors. MIL-STD 188-125A (Ref. 15) is the DoD standard that comes closest to establishing a test procedure for suppressors. It focuses on point-of-entry (POE) devices for protecting military installations from the electromagnetic pulse (EMP) that occurs when a nuclear device is detonated. This standard specifies test parameters for MOVs and GDTs, which are the devices most often used for primary POE protection under this specification, but it is silent on any other type of suppressor. MIL-STD 188-125A Appendix B Paragraph 50.4I describes using a 1mA DC clamp voltage to test MOVs. By an unofficial convention, many MOV manufacturers specify the clamping voltage of their devices at 1mA DC, so this provides some indication of the performance of a “good” device. The standby current of modern TVSS devices is much lower than 1mA, so this current places them in their “turn-on” state. The same section of MIL-STD 188-125A also specifies that the “d.c. breakdown voltage of a spark gap” be measured and compared to the device specifications.

For a clamp device, only one parameter would appear to be necessary to characterize the device: the clamp voltage. This is easily obtained by measuring the voltage appearing across the device as it first turns on (e.g., the 1mA DC clamp voltage of an MOV). For a crowbar device, two parameters are helpful: the breakover voltage (VBO) and the “turn-on” voltage (VT), which at 1mA DC is usually small enough to be considered zero. Thus any tester should be capable of measuring these parameters. An undamaged clamp device, such as an MOV, tested at 1mA DC should have VBO and VT approximately equal and close to

the specified 1mA DC clamp voltage. A crowbar device, such as a GDT, should have a VBO close to its rated DC breakover voltage and a very low VT. A GDT's VBO will vary with the rise-time of an applied pulse, so it is important for the tester to raise the applied voltage across a GDT slowly enough that it approximates the DC breakover voltage.

The two necessary parameters can be examined with a tester consisting of a 1mA ramp-from-zero current source and a voltmeter reading both peak and average voltage across the DUT, but only the peak voltage can be measured directly with ease. The average meter reading is simply the time average of the device voltage characteristic as it turns on and off from the ramping action of the tester, so we only get an indication of crowbar action and not an actual reading of the turn-on voltage, which is difficult to measure without an oscilloscope. The peak voltage is equivalent to  $V_{brk}$ , while the average tells us if the device is also "crowbaring" back to some voltage drop lower than  $V_{brk}$ . We can use this principle to meaningfully test clamp and crowbar transient suppressor devices. A front panel switch can change the display from peak-reading to average reading, and a complete test requires that both parameters be measured. Experience with field samples has shown that, especially for suppressors whose characteristics are unknown, this ability to distinguish between clamp and crowbar devices is very useful. Sometimes, simply comparing the two readings allows us to determine if a known device is behaving improperly, indicating device stress or failure.

## V. Conclusion

A simple device is not always easy to test. Transient suppressors, because of their variety and unpredictable application environment, require knowledgeable technicians and well-designed test equipment in order to be checked. Although the tester design is not complex, there are few surge suppressor testers "out there." One reason for the scarcity of testers is that the necessary components can be somewhat expensive relative to the cost of the suppressors, but as the use of surge suppression devices and their cost increases, the cost of a tester becomes justifiable. Without one it is almost impossible to determine whether a device that is visibly undamaged remains functionally sound. Secondly, the variety of devices requires a significant commitment to customer support: providing and updating detailed testing procedures and advice on testing specific devices by working with the device manufacturers. Additionally, the ability to quickly provide custom test modules that interface with the basic tester can improve testing efficiency and accuracy for agencies that, like most, use only a few types of suppressors, although the installed number of suppressors may be quite large. Virtually any device encountered in the field can be tested in this way as part of a continuous program of maintenance to further enhance public safety, revealing damaged transient suppressors so that they can be removed from service and replaced with fresh, fully-capable devices.

## VI. References

1. Martzloff, F.D. and Lai, J. Coordinating Cascaded Surge Protection Devices: High-Low versus Low-High. IEEE Transactions on Industry Applications Vol. 29 No. 4. July/August 1993.
2. Validating Surge Test Standards by Field Experience: High-Energy Tests and Varistor Performance.
3. Fenimore, C. and Martzoff, F. D. IEEE Transactions on Industry Applications Vol. 28 No. 6 November/December 1992.
4. National Electrical Manufacturers Association. Standards Publication No. TS 2: Traffic Controller Assemblies. 1992.
5. Federal Highway Administration. Type 170 Traffic Signal Control System Hardware Specification. July, 1985.
6. Croft, T. and Summers, W., Eds. American Electricians Handbook. McGraw-Hill. 1992.
7. Hey, J. and Kram, W., Eds. Transient Voltage Suppression Manual. General Electric Company. 1978.
8. ANSI C62.1 Surge Arrestors for Alternating Current Power Circuits.
9. Bartkowiak, M., Comber, M. G., and Mahan, G. D. Energy Handling Capability of ZnO Varistors. Journal of Applied Physics Vol. 79 No. 11. June 1996.
10. Bartkowiak, M., Mahan, G. D., Modine, F. A., Alim, M. A. Influence of Ohmic Grain Boundaries in ZnO Varistors. Journal of Applied Physics Vol. 79 No. 1. January 1996.
11. Leite, E.R., Varela, J.A., Longo, E. A New Interpretation for the Degradation Phenomenon of ZnO Varistors. Journal of Materials Science Vol. 27. October 1992.
12. Sonder, E., Levinson, L. M. and Katz, W. Role of Short-Circuiting Pathways in Reduced ZnO Varistors. Journal of Applied Physics Vol. 58 No. 11. December 1985.
13. Eda, K. Destruction Mechanism of ZnO Varistors Due to High Currents. Journal of Applied Physics Vol 56. 15 November 1984.
14. Brick Wall Division, Price Wheeler Corporation. Product Literature. 1996.
15. Fenimore, C. and Martzloff, F. D.. Validating Surge Test Standards by Field Experience: High Energy Tests and Varistor Performance. IEEE Transactions on Industry Applications Vol. 28 No. 6. November/December 1992.
16. Military Standard MIL-STD-188-125A: High-Altitude Electromagnetic Pulse (HEMP) Protection For Ground-Based CCCI Facilities Performing Critical, Time-Urgent Missions. Department of Defense. 15 February 1994.
17. Denny, H.W. and Rohrbaugh, J.P. Transient Protection, Grounding, and Shielding of Electronic Traffic Control Equipment. National Cooperative Highway Research Program Report 317. June 1989.
18. Harford, J. Rudy. U.S. Implements Surge Suppression Standards. CEE News Buyer's Guide. Vol. 49 No. 7. Summer 1997.
19. Sim, S.P., Robertson, M.J. and Plumb, R.G. Catastrophic and latent damage in GaAlAs lasers caused by electrical transients. Journal of Applied Physics Vol 55 No. 11. June 1984.
20. Streetman, B.G. Solid State Electronic Devices. Prentice-Hall. 1980.

## APPENDIX C. DISPLAY MESSAGE DESCRIPTIONS

Below are descriptions of different display messages you may encounter during the Start Up or the testing process.

TEST MESSAGES	
DISPLAY MESSAGE	DESCRIPTION
Voltage present Discharging xxV	Displayed when the tester detects voltage present on the suppressor that is to be tested. After the voltage is discharged, the test continues.
FWD: C = XXuF Charging YV	The tester has detected a capacitor. <b>XXuF</b> is the value of the capacitor detected. <b>YV</b> represents current voltage present on the suppressor.
Discharging xxV	The tester is discharging the voltage present on the suppressor.
FWD: Open	Displayed when the suppressor's clamping voltage is higher than 1000V.
FWD: Short Circuit	Displayed when the suppressor's clamping voltage is lower than 0.5V or the resistance between the test leads is less than 500 ohms.
FWD: Open - Low Batt	Displayed when the batteries are too low to supply enough voltage to the device under test and provide reliable measurements.
FWD: Test timed out	Unable to complete test within 20 seconds. Possible reasons include: - combination of high capacitance and high voltage - current leakage in the device under test
FWD: Av = xxV Pk = xxV	Standard test result of a suppressor without a capacitor. <b>Av</b> is the Average reading of the suppressor. <b>Pk</b> is the Peak reading of the suppressor.
FWD: C = xxuF Av = xxV Pk = xxV	Standard test result of a suppressor with a capacitor. <b>xxuF</b> is the value of the capacitor detected. <b>Av</b> is the Average reading of the suppressor. <b>Pk</b> is the Peak reading of the suppressor.
FWD: Fail: Active DUT	Unable to test due to a constant voltage present on the suppressor.

**Note:** FWD will be replaced with REV during a Reverse test.

POWER-UP MESSAGES	
#n Error	Displayed when self test fails. Contact ATSI for details. The tester will turn off in 2 seconds. To keep the message on the screen, press and hold the "ON" button.
Low Battery	Tester may not be able to test high voltage or high capacitance suppressors.
Replace Battery	Message is displayed for 2 seconds and then the tester powers down automatically.

## APPENDIX D. DEVICE-SPECIFIC TEST ROUTINES

This appendix contains the detailed test routines authored by ATSI for specific surge suppression devices. These are created in response to requests by users and to ATSI's own perceptions of which devices are most common in the traffic control and other industries that make use of the SST-450. Most test routines do not make use of specific test modules, but the more general-purpose test modules like the lead-reverser and DVM breakout/protector test modules are included in some of the discrete-device test routines because they can simplify testing operations for those devices. Occasionally, the use of a DVM or other tester is recommended for checking serial components or obtaining higher resolution measurements at low voltages (recall that the SST-450 has a display resolution of 0.1 volt).

### APPENDIX D. TABLE OF CONTENTS

Two-Terminal Gas Discharge Tube .....	31
Three-Terminal Gas Discharge Tube .....	32
EDCO SPA-100T .....	33
EDCO SRA-6LC .....	34
EDCO SRA-6LCA-916 & 716 .....	35
EDCO SHP300-10 .....	36
EDCO SPA-300.....	37
EDCO PC642, no suffix .....	38
EDCO PC642, D suffix .....	39
EDCO PC642, X or LC suffix .....	40
EDCO ACP-340 .....	41
EDCO SHA 1210 .....	42
EDCO SHA 1250 .....	43
EDCO SRA64C, no suffix .....	44
EDCO SRA64C, D suffix .....	45
EDCO SRA64C, X suffix .....	46
ISLATROL IC+ 107 .....	47
EDCO SRA16C-1 .....	48
EDCO MPA-303-6 & MPA-303-9 .....	49
EDCO MRA-6LC-6 .....	50
EDCO SRA-2LP .....	51
EDCO SPA-303.....	52

## Two-Terminal Gas Discharge Tube, up to 2kV C1.1A

REVISION DATE: 10/30/97 Initial test design

REFERENCES: MIL-STD 188-125A Appendix B, Section 50.4I



### TEST PROCEDURE:

This test should be sufficient for measuring the DC breakdown voltage of a spark gap, as defined in the reference above.

1. Remove or otherwise isolate the GDT from the circuit.
2. Attach a test clip to each terminal of the GDT.
3. Turn on the tester unit.
4. Push the FORWARD TEST button. Record the value, which is the DC break-down voltage of the GDT. Sometimes there is a visible arc within the tube during testing. This is normal, and an indication that the tube is operating by discharge, as designed (for most devices, expect an AVERAGE reading of 20-40% less than PEAK).
5. A REVERSE TEST is not required for this device type.

## Three-Terminal Gas Discharge Tube, up to 2kV C1.2A

REVISION DATE: 10/30/97

Initial test design

REFERENCES: MIL-STD 188-125A Appendix B, Section 50.4I

This test should be sufficient for measuring the DC breakdown voltage of a spark gap, as defined in the reference above.



### TEST PROCEDURE:

1. Remove or otherwise isolate the GDT from the circuit.
2. Attach a test clip to the common terminal of the GDT (usually the one in the middle). Attach the other test clip to one of the two remaining terminals.
3. Turn on the tester unit.
4. Press the FORWARD TEST button. Record the value, which is the DC break-down voltage of the GDT. Sometimes there is a visible arc within the tube during testing. This is normal, and an indication that the tube is operating by discharge, as designed (for most devices, expect an AVERAGE reading of 20-40% less than PEAK).
5. A REVERSE TEST is not required for this device type.

## EDCO SPA-100T C2.2A

REVISION DATES: 02/13/98 Initial test design

REFERENCES:

TEST PROCEDURE:



1. Remove or otherwise isolate the SPA-100T from the circuit.
2. Attach a test clip to each terminal of the device.
3. Turn on the tester unit.
4. Push the FORWARD TEST pushbutton. Record the value. The measured value for the 1mA DC breakdown of this device should be in the range of 216 and 264 volts
5. A REVERSE TEST is not required for this device type.

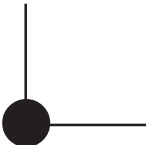

**EDCO SRA-6LC C4.1A**

REVISION DATES: 3/16/98 Initial test design

REFERENCES:

TEST PROCEDURE:



1. Remove or otherwise isolate the device from circuit. Permanently mark one of the wires to distinguish it from the other. We will call this marked wire #1. The unmarked wire is called wire #2.
2. Place the black test lead on the threaded stud.
3. Place the red test lead on wire #1.
4. Turn on the tester unit.
5. Press the FORWARD TEST pushbutton and record the display value. The PEAK breakover voltage should be between 140 and 170 volts
6. The AVERAGE voltage should be somewhat lower (about 10-30V lower) than the PEAK reading just obtained. This verifies that the crowbar device is operating.
7. Press the REVERSE TEST pushbutton and record the display values.
8. Now place the red test lead on wire #2 and place the black test lead on the threaded stud.
9. Repeat steps 5-7 with the new lead configuration.
10. Place the black test lead on wire #2 and place the red test lead on wire #1.
11. Repeat steps 5-7.

You have now thoroughly tested the SRA-6LC by examining each of its three suppressor components independently and in both directions.

## EDCO SRA-6LCA-916 & 716 C4.2A

REVISION DATES: 2/16/98 Initial test design

REFERENCES:

TEST PROCEDURE:

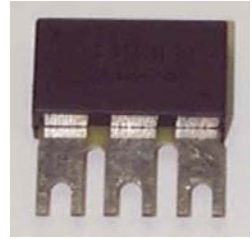

1. Remove or otherwise isolate suppressor from circuit.
2. Mark one of the outside spade terminations with a permanent mark. We will call this Terminal 1. The middle terminal is GROUND, and the terminal opposite Terminal 1 is Terminal 2.
3. Place the black test lead on the GROUND terminal. Make sure the clip contacts the metallic surface of the terminal.
4. Place the red test lead on Terminal 1.
5. Turn on the tester. Push the FORWARD TEST pushbutton. Record value. The PEAK breakover voltage should be 140 and 160 volts. The AVERAGE reading should be between 70 and 100 volts which verifies the crowbar operation of the device.
6. Turn off the tester.
7. Move the red test lead to terminal 2.
8. Repeat steps 5-6.
9. Move the black test lead to Terminal 1.
10. Repeat steps 5-6.
11. A REVERSE TEST is not required for this device type.

**EDCO SHP300-10** C5.1A

REVISION DATES: 3/16/98 Initial test design

REFERENCES:



TEST PROCEDURE:

1. Remove or otherwise isolate the suppressor from circuit. Make sure all 5 non-ground terminals are open.
2. There are 3 clamp-type suppressors in this package, and each will be tested individually in the steps below.
3. Connect the black test lead to the GND terminal of the suppressor.
4. Connect the red test lead to the MAIN LINE terminal.
5. Turn on the tester.
6. Push the FORWARD TEST button. Record the AVERAGE clamp voltage. It should be between 216 and 264 volts.
7. Turn off the tester.
8. Move the red test lead to the MAIN NEUTRAL terminal. Repeat step 5-7.
9. Move the black test lead to the NEUTRAL EQUIP terminal.
10. Move the red test lead to the LINE IN EQUIP terminal. Repeat step 5-7.
11. A REVERSE TEST is not required for this device type.

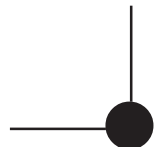

**EDCO SPA-300 C2.3A**

REVISION DATES: 3/16/98 Initial test design

REFERENCES:

TEST PROCEDURE:



1. Remove or otherwise isolate the suppressor from the circuit. For a simple suppressor like the SPA-300, it is really only necessary to remove wires from one of the terminals (for example, the hot side wires). So this suppressor is easily checked in the cabinet, but one must still switch off the AC power to the cabinet (creating a dark intersection) during the test.
2. Place the black test lead on the GND terminal.
3. Place the red test lead on the LINE terminal.
4. Turn on the tester.
5. Press the FORWARD TEST button. Record the PEAK clamp voltage. It should be between 216-264 volts.\*
6. A REVERSE TEST is not required for this device type.

\* *NOTE:* Some older cabinets occasionally contain an EDCO SPA-300 utilizing a gas discharge tube with a breakdown voltage range of 450-500V. If you think your SPA-300 is an older model, you should check to see if it contains a GDT rather than an MOV. The easiest way to do this is to check the PEAK readout value. If the average voltage is considerably lower than the peak (75V or more), then the SPA-300 is an older one that contains a GDT. If the peak and average readings are nearly identical and in the range 216-264V, the SPA-300 is newer and contains an MOV.

**EDCO PC642, no suffix** c5.4A

REVISION DATES: 3/31/98

Initial Test Design

REFERENCES:

TEST PROCEDURE:



This test procedure requires the **ST-AB-01 Adapter Module**. *Note:* these devices contain two independent suppressor circuits that are tested individually by the procedure below. Make sure to distinguish the recorded voltages as “circuit #1 line 1-to-ground, forward,” “circuit #2 line-to-ground, reverse,” etc.

1. Connect the test adapter to the SST-450.
2. Place the suppressor in the adapter socket.
3. Set the select knob to position **1**. This checks circuit **#1 line 1-to-ground**.
4. Turn on the tester unit. Be sure to perform the following test in both the FORWARD and REVERSE directions. Record both values (FWD and REV). The PEAK voltage should be:

<b>PC642C-008</b>	<b>7-9V</b>	<b>PC642C-043</b>	<b>40-46V</b>
<b>PC642C-015</b>	<b>13-17V</b>	<b>PC642C-050</b>	<b>47-53V</b>
<b>PC642C-020</b>	<b>18-22V</b>	<b>PC642C-060</b>	<b>57-63V</b>
<b>PC642C-030</b>	<b>28-32V</b>	<b>PC642C-200</b>	<b>297-303V</b>
<b>PC642C-036</b>	<b>34-38V</b>		

5. Set the select knob to position **2**. This checks circuit **#1 line 2-to-ground**.
6. Repeat step 4.
7. Set the select knob to position **5**. This checks circuit **#2 line 1-to-ground**.
8. Repeat step 4.
9. Set the select knob to position **6**. This checks circuit **#2 line 2-to-ground**.
10. Repeat step 4.
11. Turn off the tester unit.

**EDCO PC642, D suffix C5.5A**

REVISION DATES: 3/31/98

Initial Test Design

REFERENCES:

TEST PROCEDURE:



This test procedure requires the **ST-AB-01 Adapter Module**. *Note:* these devices contain two independent suppressor circuits that are tested individually by the procedure below. Make sure to distinguish the recorded voltages as “circuit #1 line 1 to-ground, forward,” “circuit #2 line 1 to-ground, reverse,” etc.

1. Connect the test adapter to the SST-450.
2. Place the suppressor in the adapter socket.
3. Set the select knob to position **1**. This checks circuit **#1 line 1-to-ground**.
4. Turn on the tester unit. Be sure to perform the following test in both the FORWARD and REVERSE directions. Record both values (FWD and REV). The PEAK voltage should be:

<b>PC642C-008D</b>	<b>60-120V</b>	<b>PC642C-043D</b>	<b>60-120V</b>
<b>PC642C-015D</b>	<b>60-120V</b>	<b>PC642C-050D</b>	<b>60-120V</b>
<b>PC642C-020D</b>	<b>60-120V</b>	<b>PC642C-060D</b>	<b>60-120V</b>
<b>PC642C-030D</b>	<b>60-120V</b>	<b>PC642C-200D</b>	<b>300-350V</b>
<b>PC642C-036D</b>	<b>60-120V</b>		

5. Set the select knob to position **2**. This checks circuit **#1 line 2-to-ground**.
6. Repeat step 4.
7. Set the select knob to position **5**. This checks circuit **#2 line 1-to-ground**.
8. Repeat step 4.
9. Set the select knob to position **6**. This checks circuit **#2 line 2-to-ground**.
10. Repeat step 4.
11. Set the select knob to position **7**. This checks circuit **#1 line-to-line**.
12. Perform the following test in both the FORWARD and REVERSE directions.

<b>PC642C-008D</b>	<b>7-9V</b>	<b>PC642C-043D</b>	<b>40-46V</b>
<b>PC642C-015D</b>	<b>13-17V</b>	<b>PC642C-050D</b>	<b>47-53V</b>
<b>PC642C-020D</b>	<b>18-22V</b>	<b>PC642C-060D</b>	<b>57-63V</b>
<b>PC642C-030D</b>	<b>28-32V</b>	<b>PC642C-200D</b>	<b>297-303V</b>
<b>PC642C-036D</b>	<b>34-38V</b>		

13. Set the select knob to position **8**. This checks circuit **#2 line-to-line**.
14. Repeat step 12.
15. Turn off the tester unit.

**EDCO PC642, X or LC suffix C5.6A**

REVISION DATES: 3/31/98

Initial Test Design

REFERENCES:

TEST PROCEDURE:



This test procedure requires the **ST-AB-01 Adapter Module**. *Note:* these devices contain two independent suppressor circuits that are tested individually by the procedure below. Make sure to distinguish the recorded voltages as “circuit #1 line 1 to-ground, forward,” “circuit #2 line 1 to-ground, reverse,” etc.

1. Connect the test adapter to the SST-450.
2. Place the suppressor in the adapter socket.
3. Set the select knob to position 1. This checks circuit #1 line 1-to-ground.
4. Turn on the tester unit. Be sure to perform the following test in both the FORWARD and REVERSE directions. Record both values (FWD and REV). The PEAK voltage should be:

**PC642C-008X/LC 7-9V****PC642C-043X/LC 40-46V****PC642C-015X/LC 13-17V****PC642C-050X/LC 47-53V****PC642C-020X/LC 18-22V****PC642C-060X/LC 57-63V****PC642C-030X/LC 28-32V****PC642C-200X/LC 297-303V****PC642C-036X/LC 34-38V**

5. Set the select knob to position 2. This checks circuit #1 line 2-to-ground.
6. Repeat step 4.
7. Set the select knob to position 5. This checks circuit #2 line 1-to-ground.
8. Repeat step 4.
9. Set the select knob to position 6. This checks circuit #2 line 2-to-ground.
10. Repeat step 4.
11. Turn off the tester unit.

## **EDCO ACP-340** C5.7A

REVISION DATES: 4/6/98 Initial Test Design

REFERENCES:

TEST PROCEDURE:



1. Remove or otherwise isolate the suppressor from the circuit.
2. Place the red test lead on the Line In terminal.
3. Place the black test lead on the GND terminal.
4. Turn on the tester. Push the FORWARD TEST pushbutton and record the clamp value. Turn off the tester. The recorded value should be 216-264 volts.
5. Place the red test lead on the Neut In terminal.
6. Repeat step 4.
7. Place the black test lead on the Neut Out terminal.
8. Place the red test lead on the Line Out terminal.
9. Repeat step 4.

**EDCO SHA-1210** C5.8A

REVISION DATES: 4/7/98 Initial Test Design

REFERENCES:

TEST PROCEDURE:



1. Remove or otherwise isolate the suppressor from the circuit.
2. Place the black test lead on the MAIN GND terminal.
3. Place the red test lead on the MAIN AC IN terminal.
4. Turn on the tester. Push the FORWARD TEST button. Record the PEAK clamp value. It should be 216-264V.
5. Turn off the tester.
6. Move the red test lead to the MAIN NEUT IN terminal.
7. Repeat steps 4-5.
8. Move the black test lead to the EQUIPMENT SIDE NEUT OUT terminal.
9. Move the red test lead to the EQUIPMENT SIDE AC OUT terminal.
10. Repeat steps 4-5.
11. A REVERSE TEST is not required for this device type.

## EDCO SHA-1250

REVISION DATES: 8/20/03 Initial Test Design

REFERENCES:

TEST PROCEDURE:



This test procedure requires the **ST-AB-01 Adapter Module**.

1. Connect the test adapter to the SST-450.
2. Place the suppressor in the adapter socket.
3. Set the select knob on the adapter box to position **1**. This will test the clamping voltage between **Line In** and **Ground**.
4. Turn on the tester. Push the FORWARD TEST pushbutton. Record the PEAK value. The voltage should be **185V - 225V**.
5. Set the select knob on the adapter box to position **2**. This will test the clamping voltage between **Neutral In** and **Ground**.
6. Repeat step 4.
7. Set the select knob on the adapter box to position **3**. Push the FORWARD TEST pushbutton. The tester should detect a capacitance during the test and the maximum voltage should be around **25V**. The voltage should not reach the clamping level due to current leakage through the internal relay and LED (*during this test, the Green LED should turn on*).

If either of the following occur:

- the voltage is significantly higher
- the Amber LED turns ON

it is recommended that the suppressor be replaced due to possible thermal damage of the MOVs. In this case, DO NOT perform the next step.

8. Press the REVERSE TEST pushbutton. The tester should detect a capacitance and the maximum voltage should be around 30V. In this case, the current is leaking through the relay ( $6K\Omega$  at 5mA of capacitor charging current). If the voltage is significantly higher, the suppressor should be replaced due to possible thermal damage of the MOVs.

**EDCO SRA64C, no suffix C5.9A**

REVISION DATES: 5/19/98

Initial Test Design

REFERENCES:

TEST PROCEDURE:

Note: Wire Colors: **W= White****K=Black****R=Red**

1. Remove the suppressor from the circuit. Tape the ends of W and W/R to prevent accidental contact.
2. Place the red test lead on the **K** wire.
3. Place the black test lead on the GND stud.
4. Turn on the tester. Push the FORWARD TEST pushbutton and record the value. The PEAK voltage should be:

**SRA64C-008 7-9V****SRA64C-043 40-46V****SRA64C-015 13-17V****SRA64C-050 47-53V****SRA64C-020 18-22V****SRA64C-060 57-63V****SRA64C-030 28-32V****SRA64C-200 297-303V****SRA64C-036 34-38V**

5. Push the REVERSE TEST pushbutton and record the values.
6. Turn off the tester.
7. Place the red test lead on the K/R wire.
8. Repeat steps 4-5.
9. Turn off the tester.

**EDCO SRA64C, D suffix C5.10A**

REVISION DATES: 5/19/98

Initial Test Design

REFERENCES:

TEST PROCEDURE:

Note: Wire Colors: **W= White**      **K=Black**      **R=Red**

1. Remove the suppressor from the circuit. Tape the ends of W and W/R to prevent accidental contact.
2. Place the red test lead on the **K** wire.
3. Place the black test lead on the **K/R** wire.
4. Turn on the tester. Push the FORWARD TEST pushbutton and record the value. The PEAK voltage should be:

<b>SRA64C-008D</b>	<b>14-18V</b>	<b>SRA64C-043D</b>	<b>60-100V</b>
<b>SRA64C-015D</b>	<b>26-34V</b>	<b>SRA64C-050D</b>	<b>60-100V</b>
<b>SRA64C-020D</b>	<b>36-44V</b>	<b>SRA64C-060D</b>	<b>60-100V</b>
<b>SRA64C-030D</b>	<b>56-64V</b>	<b>SRA64C-200D</b>	<b>300-350V</b>
<b>SRA64C-036D</b>	<b>60-100V</b>		

5. Push the REVERSE TEST pushbutton and record the values.
6. Turn off the tester.
7. Place the black test lead on the GND stud.
8. Turn on the tester. Push the FORWARD TEST pushbutton and record the value. The PEAK voltage should be:

<b>SRA64C-008D</b>	<b>60-120V</b>	<b>SRA64C-043D</b>	<b>60-120V</b>
<b>SRA64C-015D</b>	<b>60-120V</b>	<b>SRA64C-050D</b>	<b>60-120V</b>
<b>SRA64C-020D</b>	<b>60-120V</b>	<b>SRA64C-060D</b>	<b>60-120V</b>
<b>SRA64C-030D</b>	<b>60-120V</b>	<b>SRA64C-200D</b>	<b>300-350V</b>
<b>SRA64C-036D</b>	<b>60-120V</b>		

9. Push the REVERSE TEST pushbutton and record the values.
10. Turn off the tester.
11. Place the red test lead on the **K/R** wire.
12. Repeat steps 8-10.

**EDCO SRA64, X suffix C5.11A**

REVISION DATES: 5/21/98

Initial Test Design

REFERENCES:

TEST PROCEDURE:

Note: Wire Colors: **W= White**      **K=Black**      **R=Red**

1. Remove the suppressor from the circuit. Tape the ends of W and W/R to prevent accidental contact.
2. Place the red test lead on the **K** wire.
3. Place the black test lead on the **K/R** wire.
4. Turn on the tester. Push the FORWARD TEST pushbutton and record the value. The PEAK voltage should be:

<b>SRA64C-008X</b>	<b>14-18V</b>	<b>SRA64C-043X</b>	<b>60-100V</b>
<b>SRA64C-015X</b>	<b>26-34V</b>	<b>SRA64C-050X</b>	<b>60-100V</b>
<b>SRA64C-020X</b>	<b>36-44V</b>	<b>SRA64C-060X</b>	<b>60-100V</b>
<b>SRA64C-030X</b>	<b>56-64V</b>	<b>SRA64C-200X</b>	<b>300-350V</b>
<b>SRA64C-036X</b>	<b>60-100V</b>		

5. Push the REVERSE TEST pushbutton and record the values.
6. Turn off the tester.
7. Place the black test lead on the GND stud.
8. Turn on the tester. Push the FORWARD TEST pushbutton and record the value. The PEAK voltage should be:

<b>SRA64C-008X</b>	<b>7-9V</b>	<b>SRA64C-043X</b>	<b>40-46V</b>
<b>SRA64C-015X</b>	<b>13-17V</b>	<b>SRA64C-050X</b>	<b>47-53V</b>
<b>SRA64C-020X</b>	<b>18-22V</b>	<b>SRA64C-060X</b>	<b>57-63V</b>
<b>SRA64C-030X</b>	<b>28-32V</b>	<b>SRA64C-200X</b>	<b>297-303V</b>
<b>SRA64C-036X</b>	<b>34-38V</b>		

9. Push the REVERSE TEST pushbutton and record the values.
10. Turn off the tester.
11. Place the red test lead on the **K/R** wire.
12. Repeat steps 8-10.

## ISLATROL IC+107 C5.12A

REVISION DATES: 11/30/98 Initial Test Design

REFERENCES:

TEST PROCEDURE:



1. Remove or otherwise isolate the suppressor from the circuit.
2. Place the black test lead on the **LINE G** terminal.
3. Place the red test lead on the **LINE L** terminal.
4. Turn on the tester.
5. Press the FORWARD TEST pushbutton and record the AVERAGE clamp voltage. It should be **210-270V**.
6. Turn off the tester.
7. Move the red test lead to the **LINE N** terminal.
8. Turn on the tester.
9. Press the FORWARD TEST pushbutton and record the AVERAGE clamp voltage. It should be **210-270V**.
10. Turn off the tester.
11. A REVERSE TEST is not required for this device type.

Note: the IC+107 has a pulse capacitor connected L-N. The leakage associated with this capacitor prevents measurement of the L-N clamp voltage at 1mA. If the SST-450 is connected L-N on the IC+107, it will read 25-50V because the leakage resistance is typically 25K-50K ohm.

**EDCO SRA16C-1** C5.13A

REVISION DATES: 5/20/99

Initial Test Design



REFERENCES:

TEST PROCEDURE:

1. Remove or otherwise isolate the suppressor from the circuit.
2. Label the grey wires **L1** and **L2**.
3. Place the red test lead on **L1**.
4. Place the black test lead on **L2**.
5. Turn the tester on.
6. Make sure hands are clear. Press the FORWARD TEST pushbutton and record the value. It should be **15-17V**.
7. Press the REVERSE TEST pushbutton and record the value. It should be **15-17V**.
8. Turn the tester off.
9. Place the black test lead on the green wire.
10. Turn the tester on.
11. Make sure hands are clear. Press the FORWARD TEST pushbutton and record the value. It should be **60-120V**.
12. Turn off the tester.
13. Place the red test lead on **L2** (leave the black test lead on the green wire).
14. Repeat steps 10-12.

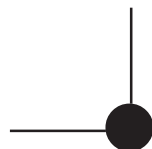

## EDCO MPA-303-9 and MPA-303-6

REVISION DATES: 10/17/03 Initial test design

REFERENCES:

TEST PROCEDURE:



This test procedure requires the **ST-AB-01 Adapter Module**. The MPA-303-6 should be plugged into positions 1-6 of the Adapter Module.

1. Connect the test adapter to the SST-450.
2. Place the suppressor into the proper adapter socket.
3. Set the select knob on the adapter box to position 1.
4. Turn on the tester unit.
5. Press the FORWARD TEST pushbutton and record the display value. The PEAK breakover voltage should be between 190 and 220 volts.
6. Press the REVERSE TEST pushbutton and record the display values. The PEAK breakover voltage should be between 190 and 220 volts.
7. Turn off the tester unit.
8. Set the select knob on the adapter box to position 2.
9. Repeat steps 4-7.
10. Set the select knob on the adapter box to position 3.
11. Repeat steps 4-7.
12. Set the select knob on the adapter box to position 4.
13. Repeat steps 4-7.

The following steps are for the MPA-303-9 only.

14. Set the select knob on the adapter box to position 5.
15. Repeat steps 4-7.
16. Set the select knob on the adapter box to position 6.
17. Repeat steps 4-7.

## EDCO MRA-6LC-6

REVISION DATES: 10/17/03 Initial test design

REFERENCES:

TEST PROCEDURE:



This test procedure requires the **ST-AB-01 Adapter Module**.

The MRA-6LC-6 should be plugged into positions 1-6 of the Adapter Module.

1. Connect the test adapter to the SST-450.
2. Place the suppressor into the proper adapter socket.
3. Set the select knob on the adapter box to position 1.
4. Turn on the tester unit.
5. Press the FORWARD TEST pushbutton and record the display value. The PEAK breakover voltage should be between 140 and 160 volts.
6. Press the REVERSE TEST pushbutton and record the display values. The PEAK breakover voltage should be between 140 and 160 volts.
7. Turn off the tester unit.
8. Set the select knob on the adapter box to position 2.
9. Repeat steps 4-7.
10. Set the select knob on the adapter box to position 3.
11. Repeat steps 4-7.
12. Set the select knob on the adapter box to position 4.
13. Repeat steps 4-7.

## EDCO SRA-2LP

REVISION DATES: 10/17/03 Initial test design

REFERENCES:

TEST PROCEDURE:



This test procedure requires the **ST-AB-01 Adapter Module**. The suppressor will test properly either way the suppressor is plugged into the adapter module.

1. Connect the test adapter to the SST-450.
2. Place the suppressor into the proper adapter socket.
3. Set the select knob on the adapter box to position 1.
4. Turn on the tester unit.
5. Press the FORWARD TEST pushbutton and record the display value. The PEAK breakover voltage should be between 140 and 160 volts.
6. Press the REVERSE TEST pushbutton and record the display values. The PEAK breakover voltage should be between 140 and 160 volts.
7. Turn off the tester unit.
8. Set the select knob on the adapter box to position 2.
9. Repeat steps 4-7.
10. Set the select knob on the adapter box to position 5.
11. Repeat steps 4-7.
12. Set the select knob on the adapter box to position 6.
13. Repeat steps 4-7.

## EDCO SPA-303

REVISION DATES: 10/17/03 Initial test design

REFERENCES:

TEST PROCEDURE:



1. Remove or otherwise isolate the suppressor from the circuit.
2. Label the Black wires #1, #2, and #3.
3. Place the black test lead on the threaded stud.
4. Place the red test lead on wire #1.
5. Turn on the tester unit.
6. Press the FORWARD TEST pushbutton and record the display value. The PEAK breakover voltage should be between 225 and 275 volts.
7. Press the REVERSE TEST pushbutton and record the display values. The PEAK breakover voltage should be between 225 and 275 volts.
8. Turn off the tester unit.
9. Move the red test lead to wire #2.
10. Repeat steps 5-8.
11. Move the red test lead to wire #3.
12. Repeat steps 5-8.